

Designing Circuits – Synthesis - Lego

Port = a pair of terminals to a cct

One-port cct; measure $I(s)$ and $V(s)$ at same port

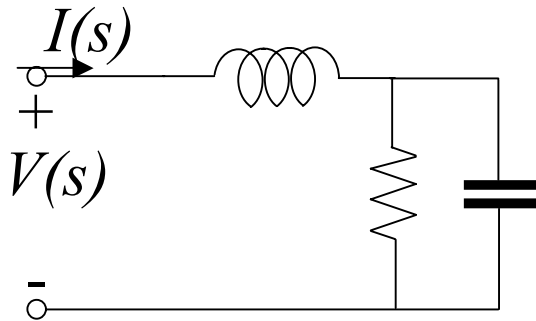

$$Z(s) = \frac{V(s)}{I(s)} = sL + \frac{1}{R^{-1} + sC}$$

Driving point impedance or input impedance $Z(s)$

Two-ports

Transfer function; measure input at one port, output at another

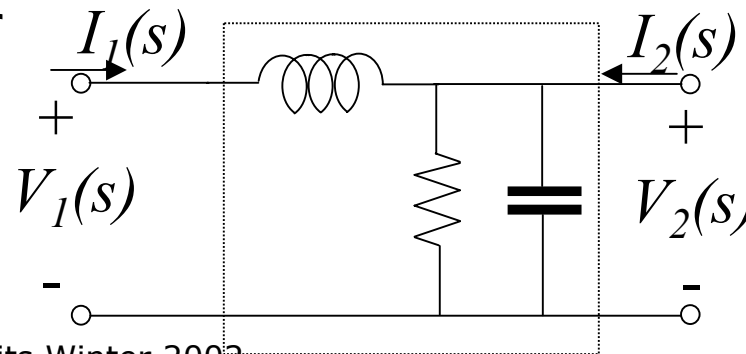

Inputs
Outputs

Cascade Connections

We want to apply a chain rule of processing

$$T_V(s) = T_{V1}(s) \times T_{V2}(s) \times T_{V3}(s) \times \dots \times T_{Vk}(s)$$

When can we do this by cascade connection of OpAmp ccts?

Cascade means output of cct_i is input of cct_{i+1}

This makes the design and analysis much easier

This rule works if stage $i+1$ does not load stage i

Voltage is not changed because of next stage

Either

Output impedance of source stage is zero

Or

Input impedance of load stage is infinite

Works well if $Z_{out,source} \ll Z_{in,load}$

Cascade Connections

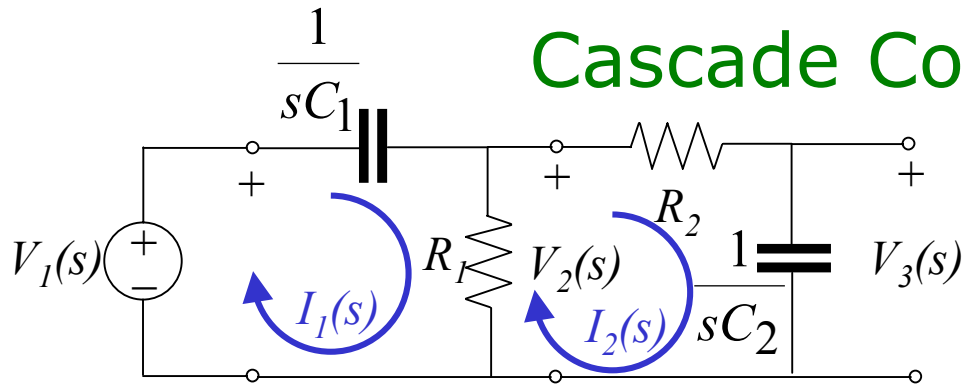

Look for chain rule

$$T_{V\text{total}}(s) = T_{V1}(s) \times T_{V2}(s) = \frac{R_1 C_1 s}{R_1 C_1 s + 1} \times \frac{1}{R_2 C_2 s + 1} = \frac{R_1 C_1 s}{(R_1 R_2 C_1 C_2) s^2 + (R_1 C_1 + R_2 C_2) s + 1}$$

Mesh analysis

$$\begin{aligned} \left(\frac{1}{sC_1} + R_1 \right) I_1(s) - R_1 I_2(s) &= V_1(s) \\ -R_1 I_1(s) + \left(R_1 + R_2 + \frac{1}{sC_2} \right) I_2(s) &= 0 \end{aligned} \quad \begin{pmatrix} I_1(s) \\ I_2(s) \end{pmatrix} = \begin{pmatrix} \frac{1}{sC_1} + R_1 & -R_1 \\ -R_1 & \frac{1}{sC_2} + R_1 + R_2 \end{pmatrix}^{-1} \begin{pmatrix} V_1(s) \\ 0 \end{pmatrix}$$

$$I_2(s) = \frac{s^2 C_1 C_2 R_1}{(R_1 R_2 C_1 C_2) s^2 + (C_1 R_1 + C_2 R_1 + C_2 R_2) s + 1} V_1(s)$$

$$V_3(s) = \frac{1}{sC_2} I_2(s) = \frac{R_1 C_1 s}{(R_1 R_2 C_1 C_2) s^2 + (R_1 C_1 + R_1 C_2 + R_2 C_2) s + 1} V_1(s)$$

Cascade Connections – OpAmp ccts

OpAmps can be used to achieve the chain rule property for cascade connections

The input to the next stage needs to be driven by the OpAmp output

Consider standard configurations

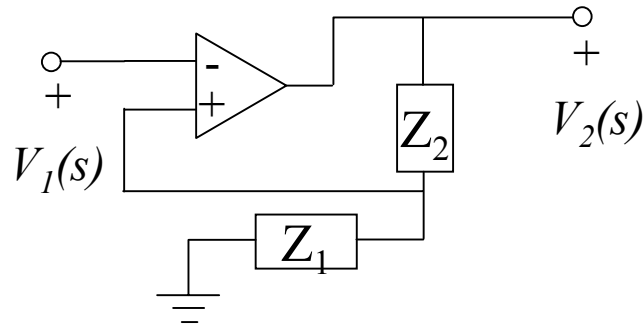

Noninverting amplifier

No current drawn from V_1 – no load

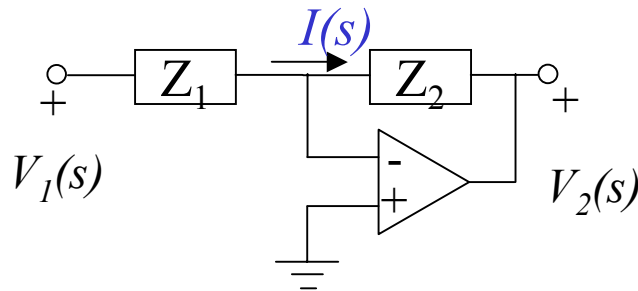

Inverting amplifier

Current provided by $V_1(s)$ $I(s) = \frac{V_1(s)}{Z_1(s)}$

Need to make sure that stage is driven by OpAmp output to avoid loading $V_1(s)$

OpAmp Ccts and transfer functions

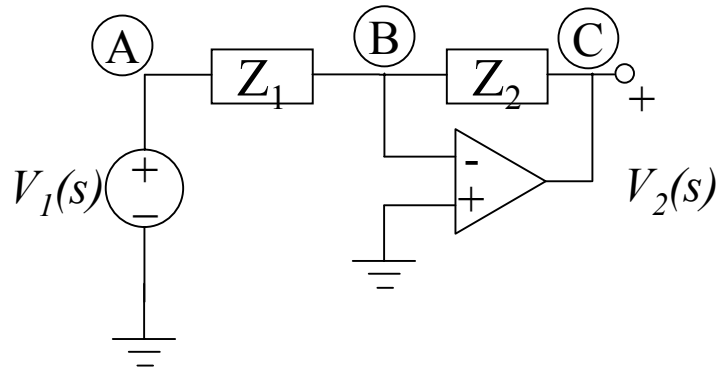

Node B:

$$\frac{V_B(s) - V_1(s)}{Z_1(s)} + \frac{V_B(s) - V_2(s)}{Z_2(s)} = 0$$

$$V_B(s) = 0 \Rightarrow T_V(s) = \frac{V_2(s)}{V_1(s)} = -\frac{Z_2(s)}{Z_1(s)}$$

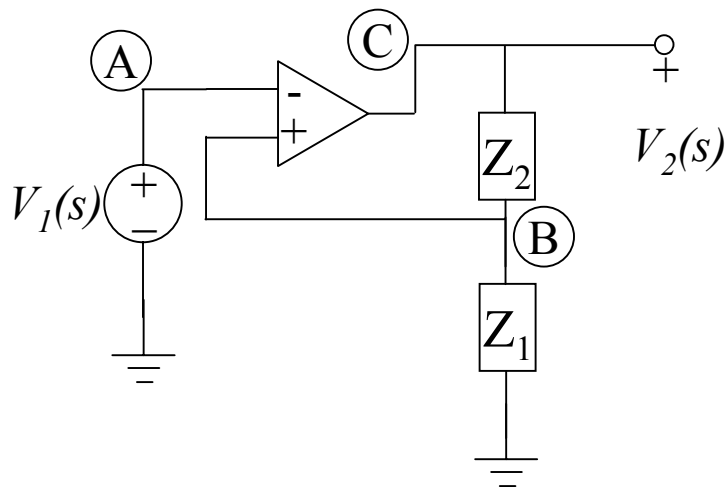

Node B:

$$\frac{V_B(s) - V_2(s)}{Z_2(s)} + \frac{V_B(s)}{Z_1(s)} = 0$$

$$V_B(s) = V_1(s) \Rightarrow T_V(s) = \frac{Z_1(s) + Z_2(s)}{Z_1(s)}$$

Example 11-4 T&R p547

Find the transfer function from $V_1(s)$ to $V_2(s)$

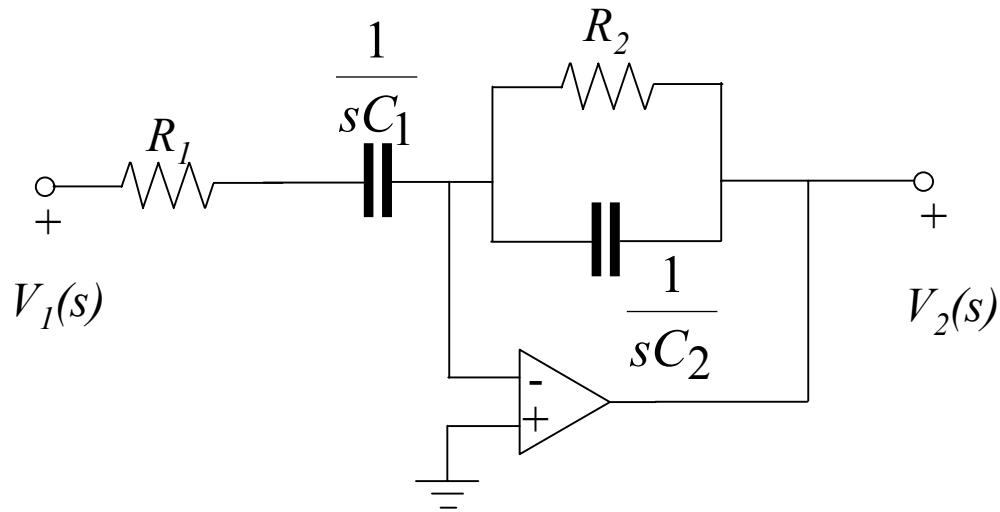

$$Z_1(s) = R_1 + \frac{1}{sC_1} = \frac{sR_1C_1 + 1}{sC_1}$$

$$Z_2(s) = \frac{R_2 / sC_2}{R_2 + 1/sC_2} = \frac{R_2}{R_2C_2s + 1}$$

$$T_V(s) = -\frac{sR_2C_1}{(sR_1C_1 + 1)(sR_2C_2 + 1)}$$

Circuits as Signal Processors

Design a circuit with transfer function

$$\frac{s^2 + 1.42 \times 10^5}{s^2 + 2 \times 10^4 s + 10^8} = \frac{(s + j2\pi 60)(s - j2\pi 60)}{(s + 10^4)^2}$$

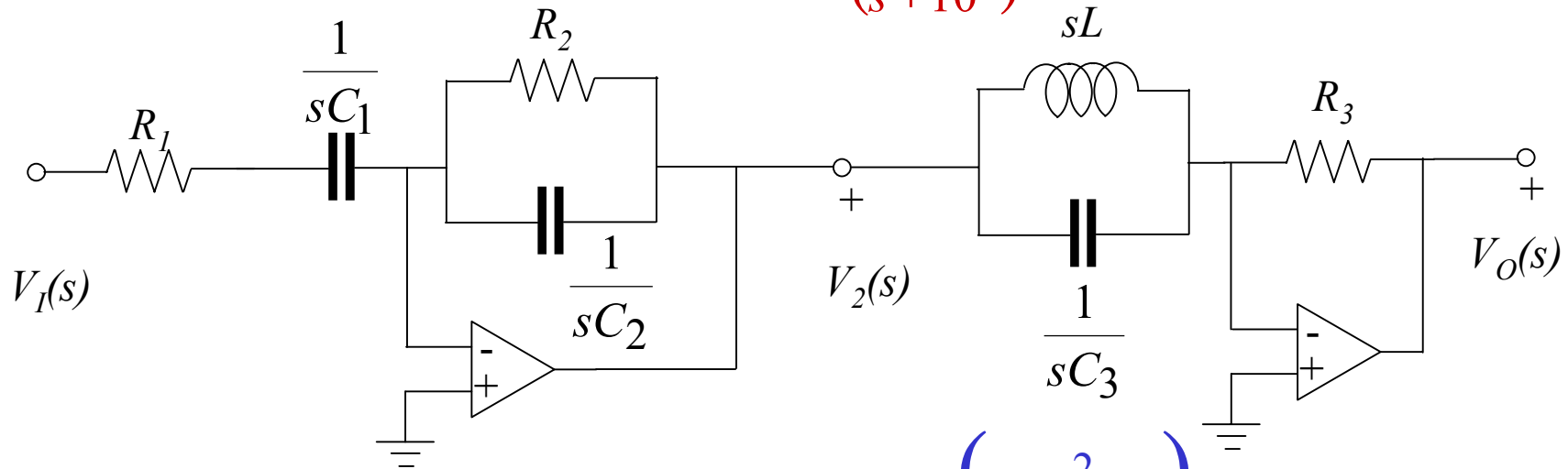

$$T_V(s) = \frac{-sR_2C_1}{(sR_1C_1 + 1)(sR_2C_2 + 1)} \times \frac{-R_3(LC_3s^2 + 1)}{Ls}$$

$R_1 = R_2 = 100\Omega$, $C_1 = C_2 = 1\mu\text{F}$, $C_3 = 100\mu\text{F}$, $L = 70\text{mH}$, $R_3 = 1\Omega$

Transfer Function Design – OpAmp Stages

First order stages

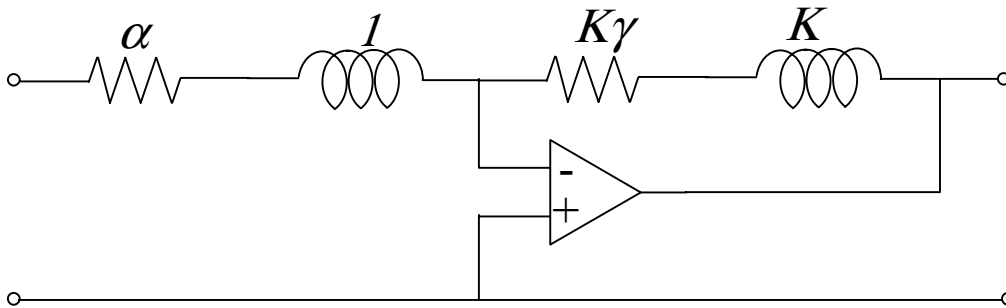

Series RL design

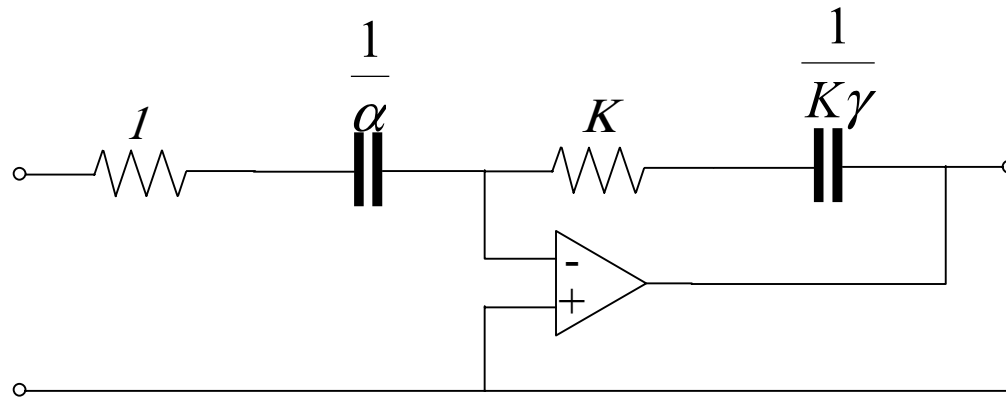

Series RC design

$$T_V(s) = -K \frac{s + \gamma}{s + \alpha}$$

First-order stages

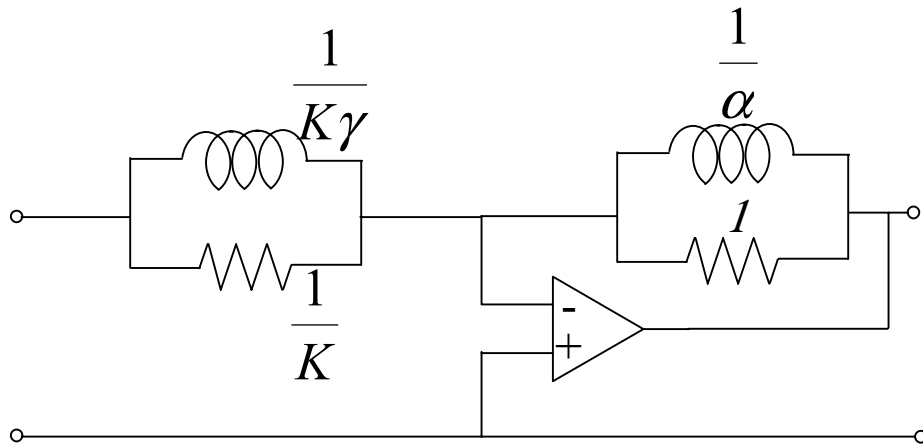

Parallel RL design

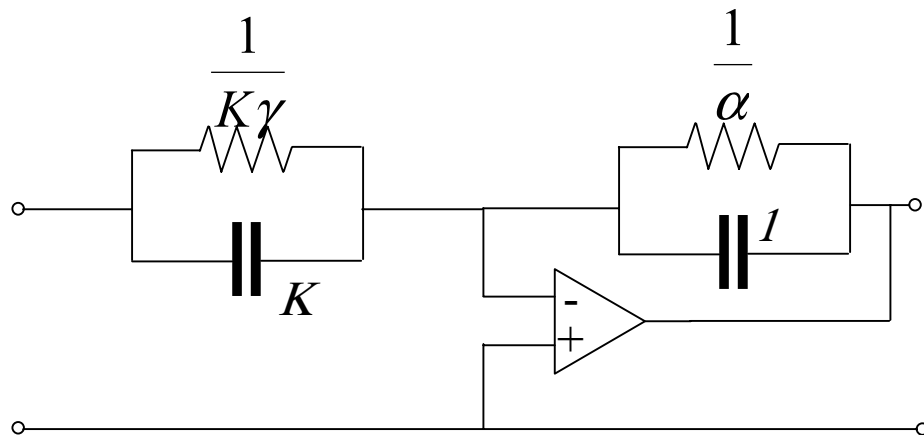

Parallel RC design

$$T_V(s) = -K \frac{s + \gamma}{s + \alpha}$$

Design Example 11-16 T&R p 572

Design two ccts to realize $T_V(s) = \frac{3000s}{(s+1000)(s+4000)}$

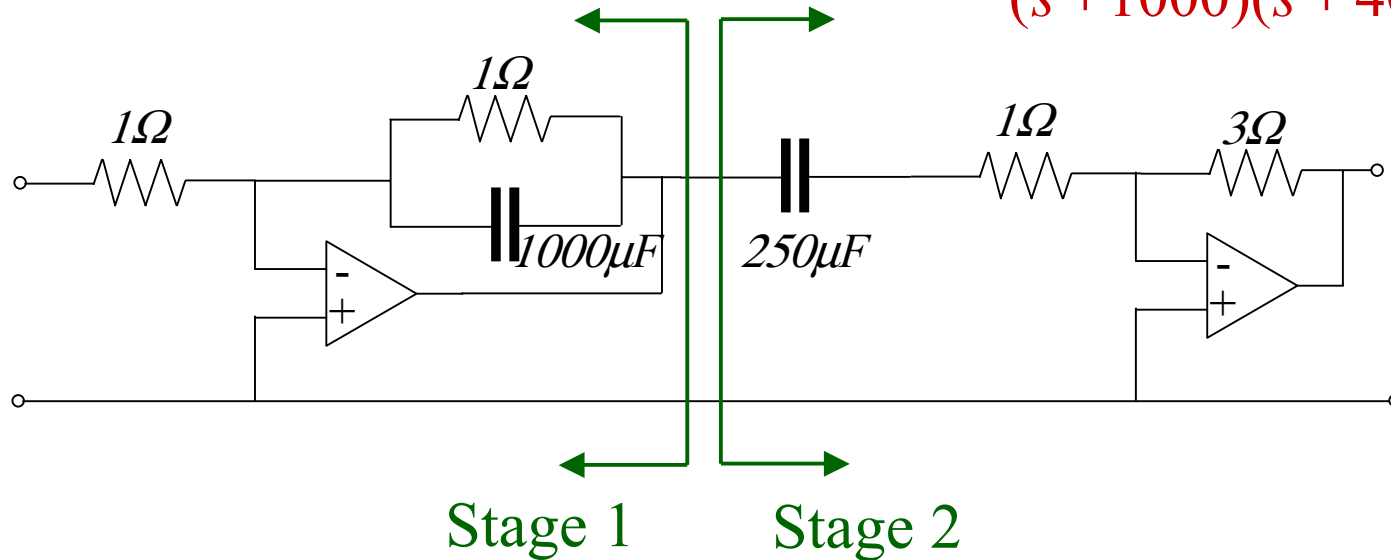

$$T_{V1}(s) = - \left[\frac{1 / 10^{-3} s}{1 + 1 / 10^{-3} s} \right] [1]^{-1} = \frac{-1000}{s + 1000} \quad T_{V2}(s) = -[3] \left[1 + 4000 / s \right]^{-1} = \frac{-3s}{s + 4000}$$

Unrealistic component values – scaling needed

Design Example 11-16 T&R p 572 contd

Non-inverting amplifier design $T_V(s) = \frac{3000s}{(s+1000)(s+4000)}$

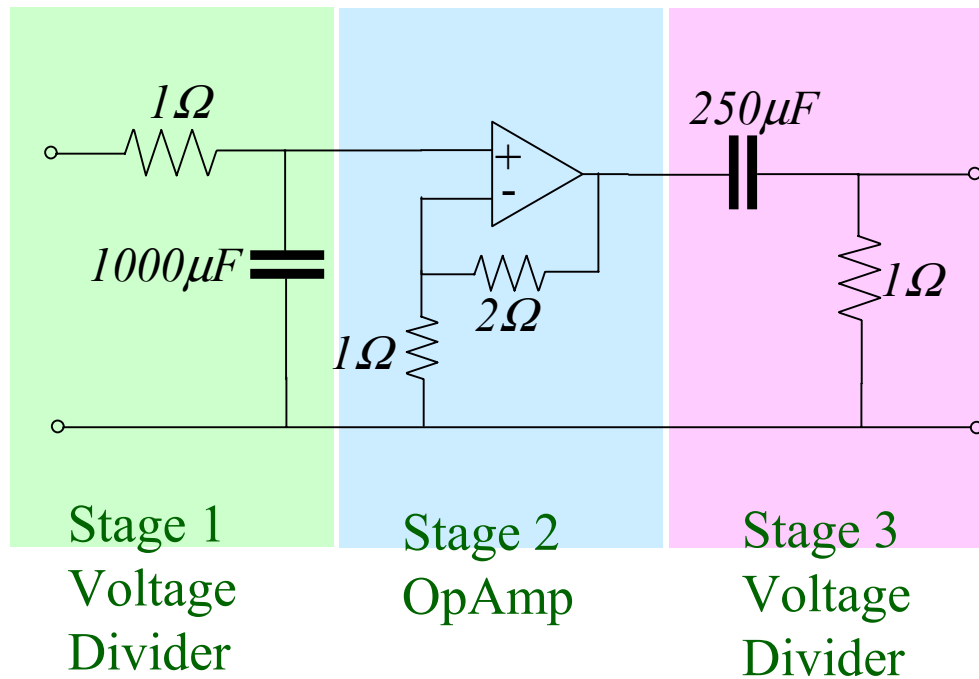

Less OpAmps but more difficult design

Three stage: last stage not driven

Unrealistic component values still – scaling needed

Scaled Design Example 11-16 T&R p 572

More realistic values for components

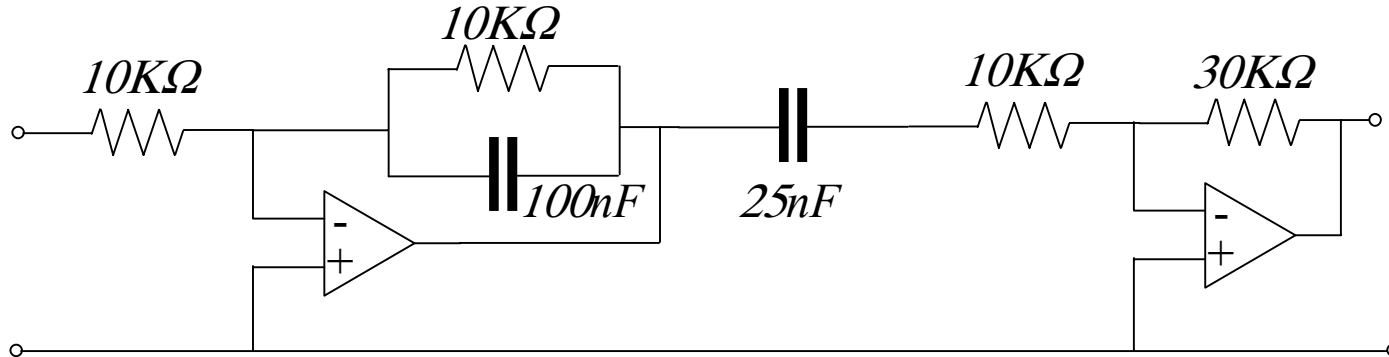

Need to play games with elements to scale

The ratio formulas for T_V help permit this scaling

It certainly is possible to demand a design T_V which is unrealizable with sensible component values

Like a pole at 10^{-3} Hz

Second-order Stage Design

Circuit stages to yield $T_V(s) = \frac{K}{s^2 + 2\zeta\omega_0 s + \omega_0^2}$

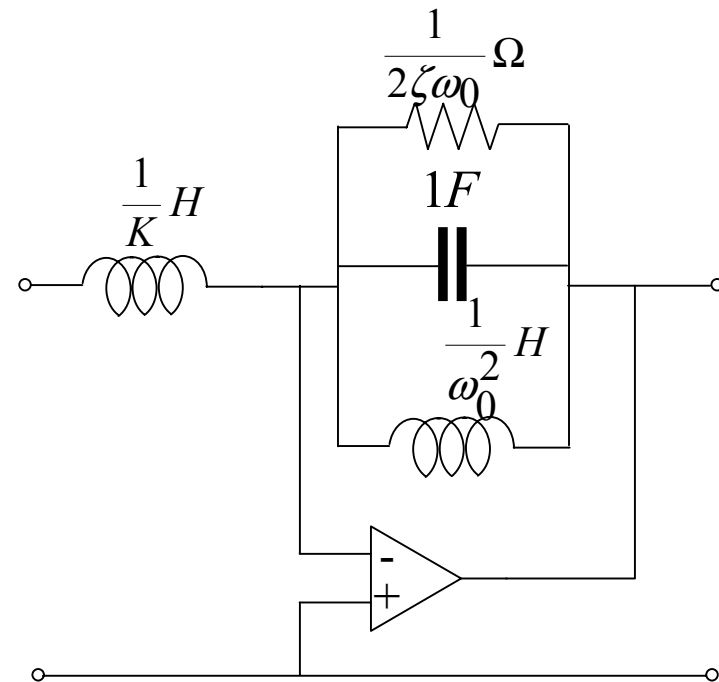
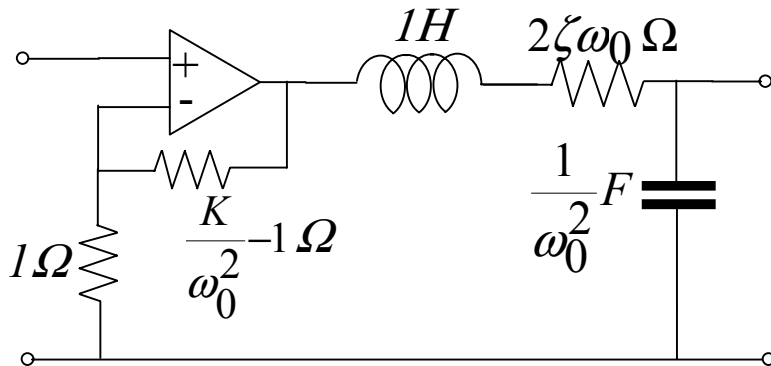
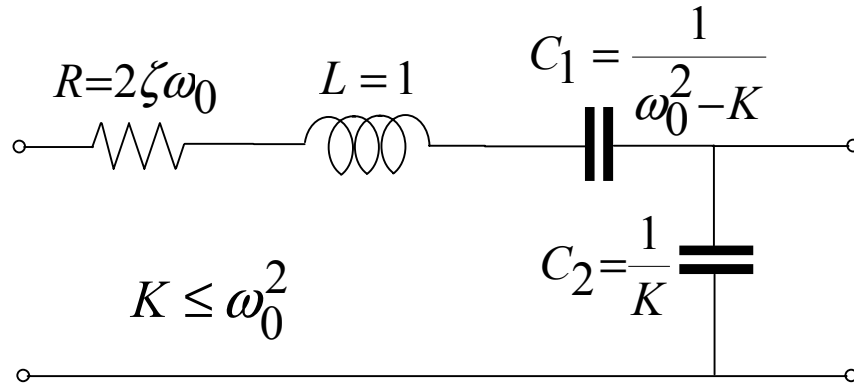

Circuit Synthesis

Given a stable transfer function $T_V(s)$, realize it via a cct using first-order and second-order stages

$$T_V(s) = \frac{\alpha s^2 + \beta s + \gamma}{as^2 + bs + c}$$

$$T_V(s) = \frac{\alpha s + \beta}{as + b}$$

We are limited to stable transfer functions to keep within the linear range of the OpAmps

There is an exception

When the unstable $T_V(s)$ is part of a stable feedback system

Come to MAE143B to find out

Transistor cct design is conceptually similar